

Equipment Required

<ul style="list-style-type: none"> • ULTRA™ Charged Particle Detector model BU-014-050-100 • 142A Preamplifier • 4001A/4002D NIM Bin and Power Supply • 575A Spectroscopy Amplifier • 807 Vacuum Chamber • 428 Detector Bias Supply • 480 Pulser • EASY-MCA-8K including a USB cable and MAESTRO software (other ORTEC MCAs may be substituted) • C-36-12 RG-59A/U 75 Ω Coaxial Cable with SHV Plugs, 12-ft (3.7-m) length. • C-24-1/2 RG-62A/U 93 Ω Coaxial Cable with BNC Plugs, 0.5-ft. (15-cm) length. • Two C-24-4 RG-62A/U 93 Ω Coaxial Cables with BNC Plugs, 4-ft. (1.2-cm) length. 	<ul style="list-style-type: none"> • Two C-24-12 RG-62A/U 93 Ω Coaxial Cables with BNC Plugs, 12-ft (3.7-m) length. • C-29 BNC Tee Connector • ALPHA-PPS-115 Portable Vacuum Pump Station • Personal Computer with a USB port and a recent, supportable version of the Windows operating system. • Access to a suitable printer for printing/plotting spectra acquired with MAESTRO. • TDS3032C Oscilloscope with a bandwidth ≥ 150 MHz. • AF200* Alpha Source Set including 0.1 μCi of ^{241}Am, 0.01 μCi of ^{228}Th and 0.01 μCi of ^{230}Th. • AF-244-A2-0.1* Alpha Source consisting of 0.1 μCi of ^{244}Cm. • Small, flat-blade screwdriver for tuning screwdriver-adjustable controls.
---	--

*Sources are available direct from supplier. See the ORTEC website at www.ortec-online.com/Service-Support/Library/Experiments-Radioactive-Source-Suppliers.aspx

Purpose

The purpose of this experiment is to familiarize the student with the use of silicon charged-particle detectors and to study some of the properties of alpha-emitting isotopes. It should take about 6 hours to complete all parts of Experiment 4. The parts are written so that they can be completed in two 3-hour laboratory periods, or certain parts can be easily omitted if equipment time is not available.

Silicon Charged-Particle Detectors

Semiconductor charged-particle detectors have been used extensively in experimental nuclear research since the early 1960s, when they revolutionized nuclear particle detection. The development rode the coattails of the emerging silicon wafer technology used in making silicon transistors. Compared to the previously employed scintillation detectors, gas proportional counters or ionization chambers, the silicon charged-particle detector offers significantly better energy resolution, excellent long-term gain stability, and much more compact size. Following the successful development of the silicon semiconductor charged-particle detector, the more difficult development of Germanium semiconductor detectors for gamma-ray spectrometry ensued. Concurrently, Si(Li) semiconductor detectors for X-ray spectrometry were also developed. Semiconductor detectors became popular because of their superior energy resolution. The better energy resolution derives from the higher number of electron-hole pairs created in silicon for a particle of energy E compared to the lower number of electron-ion pairs created in a gas proportional counter. Thus, the percent statistical fluctuation in the amount of charge collected with the semiconductor detector is smaller, and this means better energy resolution.

The semiconductor detectors for photon spectrometry will be studied in a later experiment. This experiment concentrates on the silicon semiconductor detector and its application to alpha-particle spectrometry.

Semiconductor charged-particle detectors can be used through an extensive range of energies, including 20 keV electrons on one end of the spectrum and 200 MeV heavy ions on the other. The inherent resolution of ion-implanted and surface barrier detectors is surpassed only by magnetic spectrometers. The detector output pulses rise rapidly. Hence, they are well suited for fast (~ 1 ns) timing with coincidence circuitry or time-to-amplitude converters (TACs).

The efficiency of silicon charged-particle detectors for their active volume is essentially 100%, and their energy versus pulse-height curves are linear over a rather impressive range. The remaining fact of particular interest in the educational market is that they are relatively inexpensive.

Experiment 4

Alpha Spectroscopy with Silicon Charged-Particle Detectors

Detector Operating Principles

Basically, the silicon charged-particle detector is a rather large semiconductor diode with a very thin window to allow the charged particles to enter at the front surface with minimal energy loss. By applying a reverse bias to the diode, virtually all of the free charge carriers are swept out of the sensitive depth of the diode. The depth of this charge-free zone is known as the depletion depth. The data sheet supplied with the detector will specify the reverse bias voltage required to achieve the desired depletion depth. Operating at a lower bias voltage will reduce the depletion depth. Because the front and rear electrodes form a parallel-disc capacitor, the detector capacitance is inversely proportional to the depletion depth. To achieve the best signal-to-noise ratio and good energy resolution, it is important to minimize the detector capacitance and any other stray capacitance hanging on the preamplifier input. See the ORTEC 142A/B/C Preamplifier data sheet for more information (ref. 9).

When a charged particle, such as an alpha particle, enters the detector, it loses a small amount of energy in the thin entrance window. The vast majority of its energy is deposited in the depleted region of the detector diode by causing ionization of the silicon atoms. The number of electron-hole pairs created in the silicon diode by this process is proportional to the energy of the incident alpha particle. This free charge, created by the ionization, is swept to the electrodes where it is collected on a small feedback capacitor by the preamplifier. The result at the output of the preamplifier is a pulse that rises within 1 to 100 ns to a voltage determined by the collected charge and the size of the feedback capacitor. The amplitude of this voltage step is proportional to the energy of the detected alpha particle.

To make room for successive events, the preamplifier output signal decays back to zero volts with a 50- μ s exponential decay time constant. The amplifier processes this signal by applying low-pass and high-pass filters to improve the signal-to-noise ratio and to further limit the duration of each pulse. It also applies an adjustable gain to boost the pulse heights into the range required by the Multichannel Pulse-Height Analyzer. At the output of the amplifier, the pulse height is still proportional to the energy of the detected alpha particle. The task of the Multichannel Analyzer is to sort these pulse heights into a histogram that represents the energy spectrum of the alpha particles.

For further information on the Multichannel Pulse-Height Analyzer, see the description in the Educational Experiments Library (www.ortec-online.com/Solutions/educational.aspx).

Types of Silicon Charged-Particle Detectors

The original silicon semiconductor detector used a surface-barrier contact to form the diode junction on the front surface of the detector. Essentially, this is a wisp of gold evaporated over a thin silicon oxide layer on the surface of the silicon wafer. This contact is very fragile, and one must avoid touching it. A fingerprint on the gold surface is enough to destroy the diode characteristics of the detector. Once ion-implantation technology was developed, a more rugged front contact was formed by implanting boron atoms to a controlled depth in the silicon wafer. A similar ion-implantation process with a different ion is used to form the rear contact. Although the ion-implanted window can be cleaned with alcohol on a clean, soft, cotton swab, one must avoid scratching the front surface with abrasive dust particles. The front contact is about 500 Ångstroms thick, and a small scratch can render this contact dysfunctional.

Ion-implanted detectors benefit from an order of magnitude lower leakage current, and this means lower electronic noise at longer amplifier shaping time constants. Surface-barrier detectors usually operate with a 0.5 μ s shaping time constant, whereas ion-implanted silicon detectors typically employ a 1 μ s amplifier shaping time constant.

Critical Detector Parameters

There are three main parameters that define silicon charged-particle detectors: energy resolution, active area, and depletion depth. ORTEC model numbers reflect each of these three parameters in that order. The BU-014-050-100 listed for this experiment is an ULTRA™ (ion-implanted) detector with an energy resolution <14 keV FWHM for ²⁴¹Am alphas, an active area of 50 mm², and a minimum depletion depth of 100 μ m. The letter “B” in the model number designates a Microdot connector centered on the rear of the detector, and the “U” specifies the ULTRA ion-implanted detector structure. The quoted energy resolution of an ORTEC detector is a measure of its quality. These resolutions can be measured only with a complete set of electronics, calibrated for standard conditions. The ORTEC guaranteed resolutions are measured with standard ORTEC electronics. A resolution of 20 keV or better is satisfactory for all parts of Experiment 4.

For semiconductor photon detectors, relatively simple mathematical models describe the energy resolution as a function of energy. But, charged-particle spectroscopy with silicon semiconductor detectors involves so many complicated processes, that it is not possible to describe the energy resolution versus energy with a simple mathematical model. See ref. 1, Chapters 2 and 11 for details. However, there are principles for obtaining optimum energy resolution. These involve:

Experiment 4

Alpha Spectroscopy with Silicon Charged-Particle Detectors

- Minimizing materials that can cause varying energy losses for the alpha particles as they travel to the detector.
- Minimizing the range of incidence angles with which the alpha particles impinge on the detector.
- Choosing a detector with minimum dead layer thickness and low leakage current.
- Using the optimum shaping time constant on the amplifier.
- Avoiding contamination of the detector window.
- Preventing damage to the detector front contact.

Since the shape of the detector is a circular disk, its active area is determined by the diameter of its face. At any given distance from the source, a larger area will subtend a larger angle, and thus intercept a greater portion of the total number of alpha particles that emanate from the source. A nominal area of 50 mm² is suggested for this experiment. But, any area from 25 through 100 mm² will provide the information.

The depletion depth is synonymous with the sensitive depth of the detector. For any experiment, the depth must be sufficient to completely stop all the charged particles that are to be measured. The ability to meet that requirement is dependent upon both the energy and the particle type. Fig. 4.1 is a range-energy curve for five of the more common charged particles. From that graph, the minimum depth for the maximum energy of a particle type can be determined. From Fig. 4.1, note that a 5.5 MeV alpha is completely stopped by ~27 μm of silicon. Since natural alphas are usually <8 MeV in energy, a detector with a 50 μm depletion depth is adequate to stop all natural alphas.

For an ion-implanted silicon detector, the Boron-implanted front contact causes a dead layer of approximately 500 Å thickness. Any ionization caused by the alpha particle, as it loses energy in this dead layer, recombines before it can be collected. Thus, there will be a deficit in the measured energy of the alpha particle equal to the energy the particle loses in the dead layer at the entrance window.

Fig. 4.2 illustrates the stopping power for various types of charged particles in Silicon and Germanium detectors. The stopping power in the graph is actually (1/ρ)(dE/dx), where ρ is the density of silicon (2.33 g/cm³), and dE is the incremental energy lost over the incremental distance dx. For example, a 5 MeV alpha particle will lose approximately 7 keV of energy in the 500 Å dead layer of an ULTRA ion-implanted silicon detector. Note that the rate of energy loss varies with the initial energy of the alpha-particle. See ref. 1-4, 7 and 8.

Detector Leakage Current Issues

One of the reasons for choosing an ion-implanted silicon detector instead of a surface-barrier detector is the much lower leakage current of the former compared to the latter. With a surface-barrier detector, one must always compensate for the voltage drop caused by the leakage current when setting the bias voltage. There is a 100 MΩ resistor between the BIAS input and the detector INPUT connector on the 142A Preamplifier. The function of that resistance is to suppress high-frequency noise from the bias supply, and allow virtually all of the charge from the detector to reach the preamplifier input.

Surface-barrier detectors have a typical leakage current of the order of 50 nA. Such a high leakage current would cause a 5 V drop in voltage across the 100 MΩ resistor. Therefore, one would have to raise the voltage of the detector bias supply by 5 V above the desired bias voltage to achieve the specified bias voltage at the detector. This can be a significant adjustment when the bias voltage for the detector is normally in the range of 50 to 100 V.

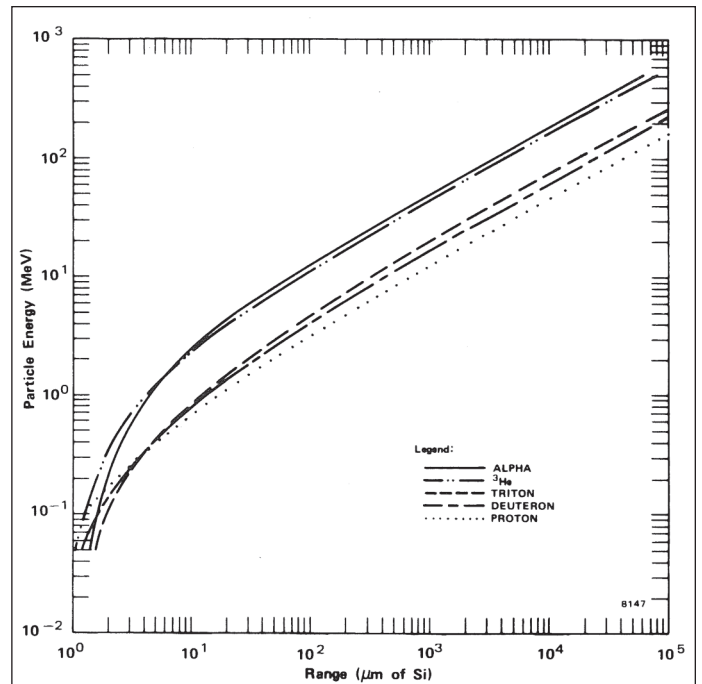

Fig. 4.1. Range-Energy Curves for Charged Particles in Silicon. [Data taken from ref.10.]

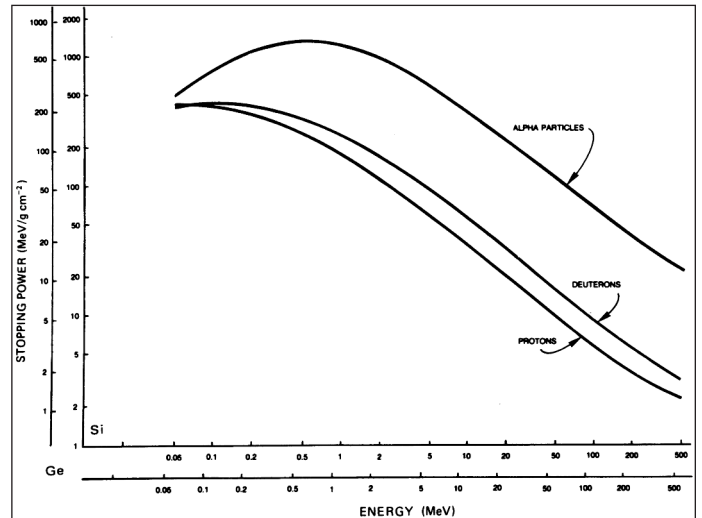

Fig. 4.2. Stopping power vs. Energy for Protons, Deuterons, and Alpha Particles in Si and Ge.

Experiment 4

Alpha Spectroscopy with Silicon Charged-Particle Detectors

For ion-implanted silicon detectors, leakage currents are normally of the order of 1 nA at room temperature. That leakage current will increase by about a factor of 2 for every 7°C increase in temperature. Such low leakage currents generate a voltage drop of the order of 0.1 V across the 100 MΩ detector bias resistor. Thus, there is no need to compensate for the voltage drop with ion-implanted silicon detectors.

Alpha Sources

CAUTION: Alpha sources offer a potential contamination problem. Never touch the face of a source with your fingers. Most alpha sources are electrodeposited onto platinum disks. The actual radioactive source is usually a spot ~1 mm diameter deposited in the geometrical center of the disk. If you look carefully, you may be able to see the deposited spot. ALWAYS handle an alpha source by the edge of the mounting disk.

Because alpha-particles lose energy easily in thin layers of material, the deposited radioactive material must be very thin, and the sources must have either no window or an extremely thin window over the deposited radioactive material. Any significant energy loss in the radioactive material or the window will reduce the measured energy of the alpha particle, and variations in that energy loss will broaden the energy resolution in the acquired spectrum. Dirt or other contamination that collects on the surface of the source can also contribute to undesirable energy loss and resolution broadening. Therefore the source should always be stored in a protective container when not in use. The absence of a protective window over the source means that there is potential for the radioactive material to be knocked loose from the source substrate and to disperse into surrounding areas. Some naturally-occurring alpha-emitters decay into a radioactive daughter isotope that is a gas (Radon). This gas can leave the source and cause contamination of the surrounding environment with its radioactive daughter isotopes.

Because of the issues with migration of the radioactive source material and dirt deposits on the surface of the source, alpha-source manufacturers generally recommend replacing the alpha source every two years.

For further advice on alpha sources consult ref. 10.

EXPERIMENT 4.1. Simple Alpha Spectrum and Energy Calibration with a Pulser

Procedure

Connecting the Electronic Instruments.

1. Set up the equipment as shown in Fig. 4.3, with the 807 Vacuum Chamber connected to the ALPHA-PPS-115 Portable Vacuum Pump Station via the vacuum hose.
2. Check that the ULTRA Charged Particle Detector model BU-014-050-100 has been properly installed in the vacuum chamber lid.
3. To minimize the stray capacitance on the preamplifier input, connect the detector output to the 142A Preamplifier INPUT using the shortest possible 93 Ω coaxial cable (C-24-1/2).
4. Check that the SHAPING TIME switches accessible through the side panel of the 575A Amplifier are all set to 1.5 μs.
5. Turn off power to the 4001A/4002D NIM Bin and Power Supply, and insert the 480 Pulser, 428 Detector Bias Supply, and 575A Amplifier in the NIM Bin.
6. Connect the captive power cable on the 142A Preamplifier to the PREAMP POWER connector on the rear panel of the 575A Amplifier.
7. Using a 3.7 m, 93 Ω, coaxial cable, connect the Preamplifier “E” (Energy) output to the INPUT of the 575A Amplifier. Set the 575A input polarity to POSitive.
8. On the 428 Detector Bias Supply, set both voltage dials to their minimum value (zero). Turn the POS/OFF/NEG switch to the OFF position.

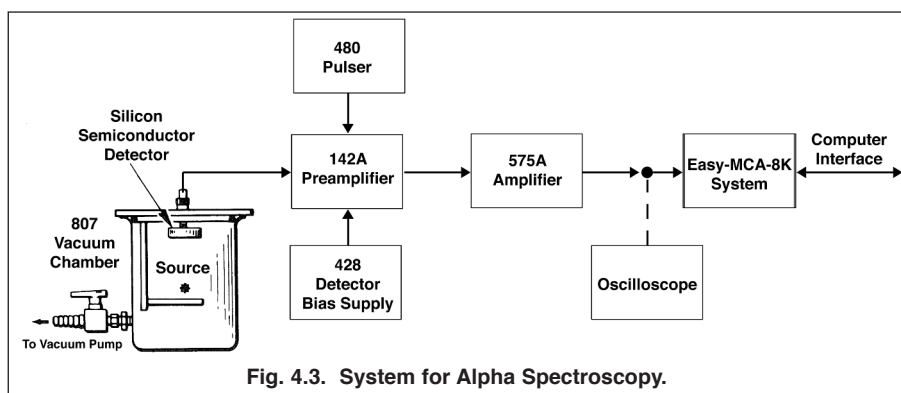

Experiment 4

Alpha Spectroscopy with Silicon Charged-Particle Detectors

9. Connect the A OUTPUT of the 428 to the BIAS input on the 142A Preamplifier, using the C-36-12 coaxial cable with SHV connectors.
10. Using a 3.7 m, 93 Ω , coaxial cable, connect the ATTENUATED OUTPUT of the 480 Pulser to the TEST input of the 142A Preamplifier. Verify that the 100 Ω Terminator is applied to the DIRECT OUTPUT on the 480. Set the output polarity to NEGATIVE and turn the ON/OFF switch to OFF.
11. Using 1.2 m, 93 Ω , coaxial cables, connect the UNIPOLAR OUTPUT of the 575A Amplifier to one leg of a BNC Tee on the Channel 1 Input of the oscilloscope. Connect the other leg of that BNC Tee to the analog INPUT of the EASY-MCA-8k.
12. Using the USB cable, connect the USB port on the rear of the EASY-MCA to the USB port on the supporting computer. Ensure that the MAESTRO software that operates the EASY-MCA has been installed on the computer. Select a Conversion Gain of 8192 channels full scale for the MCA digital resolution. Set the Lower level Discriminator to circa 80 channels and the Upper Level Discriminator to 8192 channels. Check that the Gating function is turned off.
13. Turn on power to the computer and the NIM Bin and Power Supply. **BUT AVOID TURNING ON BIAS VOLTAGE TO THE DETECTOR WHILE IT IS EXPOSED TO LIGHT.** Although the 100 M Ω bias resistor in the 142A Preamplifier will protect the detector against irreversible damage, exposure to light will cause a very high current to flow through the detector. Detector bias voltage should only be applied when the detector is in the light-tight vacuum chamber, and the air has been evacuated from the chamber.

Installing the Radioactive Source

14. For Experiment 4.1, install the ^{241}Am alpha-source from the Alpha Source Set in the source holder attached to the lid of the 807 Vacuum Chamber.
15. Adjust the distance from the alpha source to the detector to about 1 cm (inside the 807 Vacuum Chamber).
16. Place the lid on the chamber, and pump the vacuum in the chamber down to 500 μm or less. If a vacuum gauge is not available, a pumping time of 2 minutes is usually adequate. Alternatively, one can wait until the vacuum pump noise subsides to conclude that the 500 μm vacuum has been reached.
17. Turn the POS/OFF/NEG switch on the 428 Bias Supply to the POS position and raise the voltage with dial A slowly to the value recommended on the detector data sheet. Usually, this will require a dial reading in the range of 50/1000 to 100/1000 (i.e., 50 V to 100 V). If you have reason to believe that the detector leakage current is larger than 10 nA, compensate for the resulting voltage drop, as taught in the paragraphs above on Detector Leakage Current Issues.
18. Adjust the gain of the 575A Amplifier until the positive pulse amplitude observed on the oscilloscope is ≈ 5.5 V. Once the gain is set, lock the amplifier dial setting. Changing the gain of the amplifier will require an entirely new energy calibration. The ^{241}Am alpha source used for this example has three notable alpha energies as exhibited in Fig. 4.4. The dominant counting rate (84%) is associated with the 5.486 alpha energy (Fig. 4.5). The source activity ($\sim 0.1 \mu\text{Ci}$) and the counting geometry are such that the pulse rate should be adequate for oscilloscope observation of the dominant pulses of that energy.
19. Perform the Pole-Zero Adjustment as follows. Turn the oscilloscope horizontal scale to 50 μs per major division. Increase the vertical scale sensitivity one step at a time, progressing towards the 1 mV/cm scale. The oscilloscope triggering may have to be adjusted on each scale. If the pulse shape suffers abnormal distortion between two sequential vertical scales, return to the last less-sensitive scale that avoids distortion. Turn the PZ ADJ

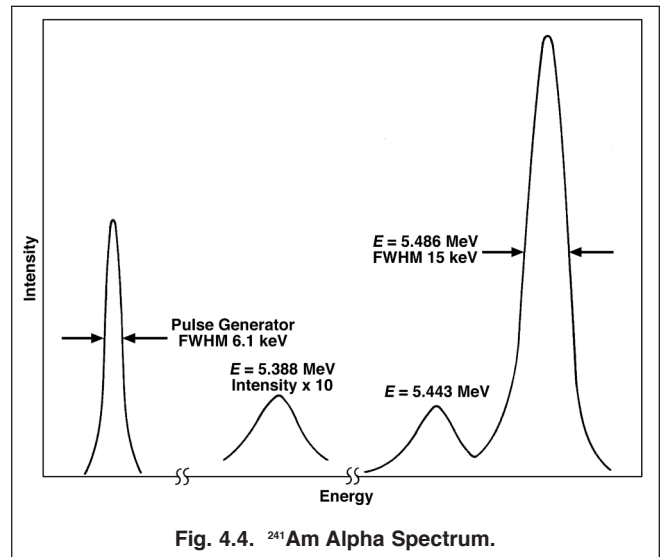

Fig. 4.4. ^{241}Am Alpha Spectrum.

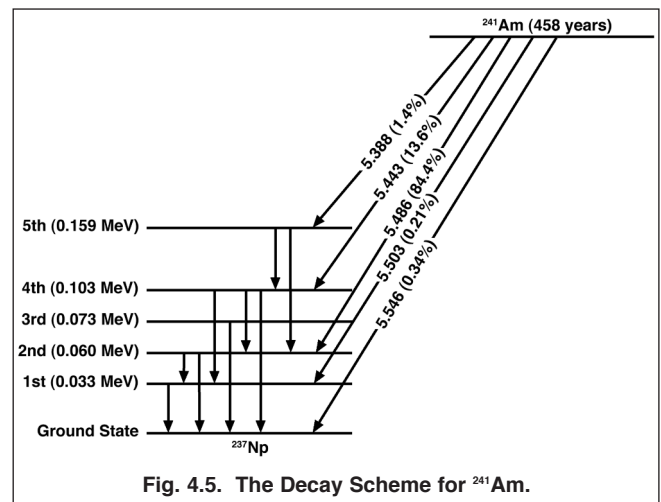

Fig. 4.5. The Decay Scheme for ^{241}Am .

Experiment 4

Alpha Spectroscopy with Silicon Charged-Particle Detectors

screwdriver adjustment on the 575A amplifier clockwise and/or counter-clockwise, as needed, to make the pulse return to baseline as quickly as possible without undershooting the baseline. When the adjustment is satisfactorily completed, return the vertical scale to 2 V per major division, and the horizontal scale to 2 μ s per major division.

20. Acquire the ^{241}Am spectrum in the MCA long enough to have at least 900 counts in the peak channel at 5.486 MeV. The spectrum should resemble that in Fig. 4.4. Determine the centroid channel number for the 5.486 MeV alpha peak. Call this channel C_0 .
21. Note the height of the 5.486 MeV peak in counts. Calculate half that maximum number of counts, and identify the half-maximum-height points on both sides of the peak. Count the number of channels between the two half-maximum-height points, and record that number as δ , the Full Width at Half Maximum height (FWHM), measured in number of channels. It may be advantageous to interpolate to a fraction of a channel on either side of the peak.
22. Turn on the 480 Pulser and set its PULSE-HEIGHT dial at 548/1000. Adjust the ATTENUATORS and the CALibration control until the pulse generator output is ≈ 5.5 V in amplitude. The output pulses from the 575A Amplifier for the pulse generator input should now be approximately the same amplitude as the pulses from the ^{241}Am alphas. The pulses from both sources can be observed simultaneously on the oscilloscope.
23. With dial A on the 428 HV Bias Supply, lower the detector bias voltage to zero. Gently release the vacuum on the 807 chamber, and remove the ^{241}Am source from the chamber.
24. Put the lid back on the chamber, and pump the vacuum to $<500 \mu\text{m}$. Slowly, restore the detector bias voltage to the value specified for the detector.
25. Clear the contents of the MCA memory. Accumulate the Model 480 pulses in the MCA for ~ 20 seconds. Do they fall above or below channel C_0 ? Adjust the CALibrate control on the pulser as necessary to center the peak exactly on channel C_0 . The pulser is now calibrated to the system so that 5.48 MeV corresponds to 548/1000 on the pulse-height dial. Therefore, any setting of the pulse-height dial represents an identified energy level. For example, 600/1000 = 6 MeV, etc.
26. Clear the MCA and accumulate the pulser pulses for ~ 20 seconds at each of the pulse-height values in Table 4.1. Determine their centroid positions with the cursor of the MCA. Alternatively, a Region of Interest (ROI) can be set across each peak and the MAESTRO features can be used to read the centroid of each ROI.

Table 4.1. Channel Numbers for Equivalent Energies

Accumulation Time (approx. s)	Pulse-Height Dial Setting	Equivalent Energy (MeV)	Channel Number of MCA Peak
20	100/1000	1.0	
20	200/1000	2.0	
20	300/1000	3.0	
20	400/1000	4.0	
40	500/1000	5.0	
20	600/1000	6.0	
20	700/1000	7.0	

EXERCISES

- a. Fill in the column of data that is missing in Table 4.1. Make a plot on linear graph paper of energy (MeV) vs. channel number. Alternatively, the graph can be plotted using an Excel spreadsheet. Compare this plot with that in Fig. 4.6. For identification purposes, the 5 MeV point is accumulated for 40 seconds.
- b. How does the energy loss in the dead layer at the detector entrance window affect the energy calibration curve?
- c. The slope of the curve in Fig. 4.6, $\Delta E/\Delta C$, is the energy per channel. For convenience this is usually expressed in keV/channel, and in the Fig. 4.6 example it is ~ 10 keV/channel. Determine the keV/channel for the plot you made in Exercise a. For the EASY-MCA-8K the number should be in the neighborhood of 1.25 keV/channel.
- d. The energy resolution in a spectrum is calculated as follows:

$$\text{Energy Resolution (keV)} = \frac{\Delta E}{\Delta C} \times \delta \quad (1)$$

where δ is the FWHM expressed in channels.

Using the δ recorded in step 21, calculate the energy resolution of your alpha peak.

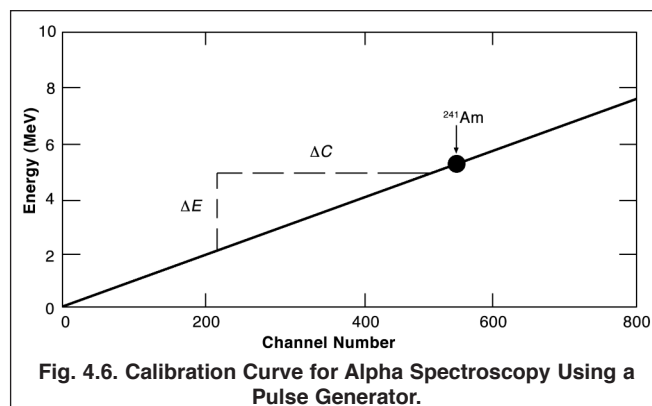

Fig. 4.6. Calibration Curve for Alpha Spectroscopy Using a Pulse Generator.

Experiment 4

Alpha Spectroscopy with Silicon Charged-Particle Detectors

- e. How does your measured energy resolution compare to the guaranteed resolution on the detector data sheet (i.e., the 14-keV number in the BU-014-050-100 model number)? Elaborate on the possible reasons for the difference. Candidates for discussion are: overly conservative specification, dirt on the detector surface or radioactive source surface, source thickness, source window, resolution was warranted on a 570 Amplifier with a 1.0 μ s shaping time constant, too few channels across the peak to make an accurate measurement, and/or inadequate counting statistics.

EXPERIMENT 4.2. Energy Calibration with Two Alpha Sources

Of course, an energy calibration can be made by employing two alpha sources; for example, ^{244}Cm , with alpha energies 5.805 MeV (77%), and 5.763 MeV (23%), along with ^{230}Th , having alpha energies 4.688 MeV (76%) and 4.621 MeV (24%). The numbers in parentheses report the percent of the decays resulting in the emission of alpha particles with the associated energy. Fig. 4.7 shows the spectrum and decay scheme for the ^{230}Th source.

Procedure

1. Turn off the pulse generator, lower the detector bias voltage to zero, and vent the vacuum chamber.
2. Place the ^{244}Cm source in the vacuum chamber, pump down, and set the bias voltage.
3. Acquire a spectrum with the ^{244}Cm source until the 5.805 MeV peak is well enough defined to measure its peak position accurately. Using the cursor, measure the channel number of the peak position and record it. It may be useful to interpolate to a fraction of a channel.
4. Save a copy of the ^{244}Cm spectrum on the hard disk for future reference, in case you need it.
5. Turn the detector bias voltage to zero and vent the vacuum chamber. Replace the ^{244}Cm with the ^{230}Th source.
6. Pump down the chamber, and set the detector bias voltage to the proper value.
7. Without erasing the previous spectrum, accumulate the ^{230}Th peaks until they are well enough defined to measure their channel position. Using the cursor, determine the position of the 4.688 MeV peak and record that value. Save a copy of the combined spectrum on the hard disk, in case you need it later.

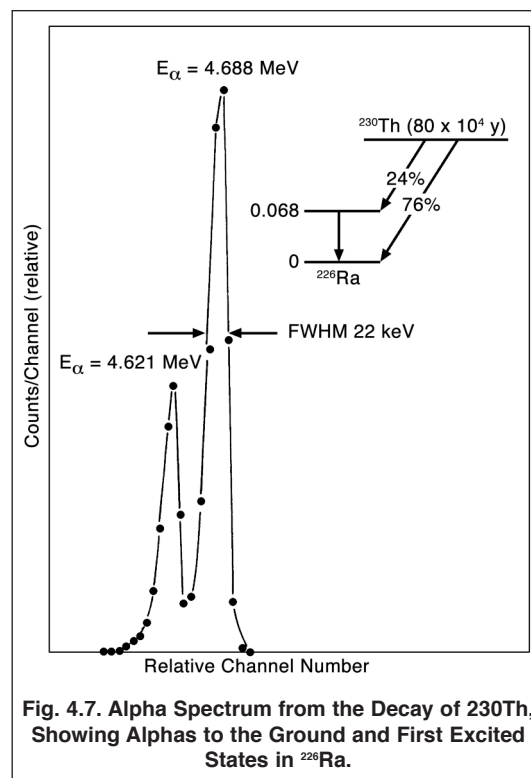

EXERCISE

- Plot the energy versus channel number points for the 5.805 MeV and 4.688 MeV peaks on the calibration curve developed with the pulser in Experiment 4.1.
- Do the points from the alpha particles fall on the pulser calibration curve? If not, explain the discrepancy.
- Use the energy calibration feature of the MAESTRO software to calibrate the cursor to readout in energy. Employ all the well-defined peaks in the composite spectrum acquired above.

EXERCISE

- How does the keV/channel slope of the calibration curve in step 8 differ from the slope determined with the pulser?
- Discuss the strengths and weakness of the three calibration methods: i) pulser matched to one alpha source energy, ii) calibration using a limited range of alpha-particle energies, and iii) combining multiple source peaks with the pulser peaks for calibration.
- A finite source thickness or an inadequate vacuum causes the alpha particles to lose varying amounts of energy before reaching the detector. Under such conditions, the alpha peaks in the spectrum will no longer be symmetric about the point of maximum counts on each peak. The high-energy side of the peak will fall towards zero counts more rapidly than the low-energy side of the

Experiment 4

Alpha Spectroscopy with Silicon Charged-Particle Detectors

peak, and a noticeable tail may be observable on the low-energy side. Under these conditions, why is it inadvisable to use the centroid of the peak for determining the energy calibration?

.....

EXPERIMENT 4.3. Absolute Activity of an Alpha Source

Purpose

The purpose of this experiment is to determine the absolute activity of an alpha source, which in this case is ^{241}Am .

As was mentioned earlier, ion-implanted and surface barrier detectors are essentially 100% efficient for their active area. It is, therefore, quite easy to determine an unknown source activity.

Procedure

1. Turn the detector bias voltage to zero, vent the chamber, and remove the ^{230}Th source.
2. Measure the active diameter of the detector, taking care not to touch or scratch the sensitive front window.
3. Carefully place the ^{241}Am source in the 807 Vacuum Chamber exactly 4 cm from the face of the detector.
4. Pump down the vacuum chamber and adjust the detector bias voltage to its proper value.
5. Use the 575A Amplifier settings employed in the previous parts of Experiment 4. Accurate energy calibration is not critical, as long as it is possible to observe and identify the three alpha peaks from ^{241}Am .
6. Erase the spectrum in the MCA memory and acquire the new spectrum for a live time that is long enough to generate at least 2,000 counts in the sum of the areas of the three peaks.
7. Save a copy of the spectrum on the hard disk in case you will need it later.
8. Set a region of interest (ROI) across the full extent of the 5.388 MeV, 5.443 MeV, and 5.486 MeV peaks. Measure the gross counts in the ROI, and record that number as Σ_α .
9. Calculate the activity of the source from the following expression:

$$\text{Activity (alphas per second)} = \left(\frac{\Sigma_\alpha}{t_L} \right) \left(\frac{4\pi s^2}{\pi r^2} \right) \quad (2)$$

where

s = distance from source to detector (4 cm in our example),

r = radius of the detector (cm),

t_L = live time in seconds,

Σ_α = sum under the three alpha peaks.

Since $1 \mu\text{Ci} = 3.7 \times 10^4$ disintegrations/second, the answer from Eq. (2) can easily be converted to μCi .

.....

EXERCISE

- a. Compare the activity calculated from Eq. (2) with the actual source activity. (If it is not written on the source, the laboratory instructor will supply the activity of the source). Eckert & Ziegler warrant that the source activity will be within $\pm 30\%$ of the activity ordered.
 - b. Does your measurement agree with the known activity within 30%?
 - c. Will the half-life of ^{241}Am have an effect on the measured activity compared to the known activity on the date of manufacture?
-

EXPERIMENT 4.5. Decay Ratios for ^{241}Am

Procedure

1. Either use the spectrum acquired and saved in Experiment 4.4, or clear the MCA and accumulate the ^{241}Am spectrum long enough to achieve good statistical definition, similar to that in Fig. 4.4.
2. From the MCA, determine the sum under the 5.486 MeV peak. Call this the sum Σ_2 since it comes from alpha decay to the second excited state of ^{237}Np (Fig. 4.5). In the same manner, determine Σ_4 (5.443 MeV peak) and Σ_5 (5.388 MeV peak).

EXERCISE

- a. With $\Sigma_T = \Sigma_2 + \Sigma_4 + \Sigma_5$, the decay ratio for α_2 (5.486 MeV) = Σ_2/Σ_T . From your data, determine the decay ratios for α_2 , α_4 , and α_5 . How do your values compare with those in Fig. 4.5?

EXPERIMENT 4.6. Isotope Identification in the ^{228}Th Decay Series

Purpose

The purpose of this experiment is to measure the alpha emission energies in the spectrum from a ^{228}Th radioactive source, and thereby identify the radioisotopes in the decay series that generated the related peaks in the spectrum.

Relevant Information

In the atomic mass number range from 206 to 238, there are four families of naturally occurring radioactive decay sequences, where the decay from the initial parent isotope begins a cascade through a series of unstable daughter isotopes before finally ending up with a stable nucleus that exhibits no further decay (ref. 11). These cascades proceed via a combination of alpha and β^- decay. The ^{228}Th isotope is a member of one of those series, as illustrated in Figure 4.8. The three radioisotopes that precede ^{228}Th in the natural series have been omitted from the illustration, because the ^{228}Th provided with this experiment has been produced artificially. This particular sequence ends with ^{208}Pb , which is not radioactive.

Table 4.2 provides the details on the type of decay and the major alpha and β^- energies for each isotope. Alpha emissions below 1% relative abundance for each isotope have been omitted for simplicity. The energies listed for the beta emissions are the endpoint energies of the broad energy hump that beta decay produces. Aside from providing a more complete picture of the decay process, the beta decay energies in Table 4.2 can be ignored in this experiment. The 100 μm depletion depth of the BU-014-050-100 ion-implanted detector is adequate to completely capture the energy of alpha particles up to at least 10 MeV. However, beta particles are much more penetrating, and the depletion depth of this detector is only adequate to stop beta particles having energies less than 0.15 MeV. Consequently, the beta decays will contribute counts in the spectrum only in the region below circa 200 keV, and that will not interfere with the alpha particle spectroscopy from 5 to 9 MeV. Internal conversion electrons (ref. 11) have also been ignored, because their low energies place them at the bottom end of the energy spectrum.

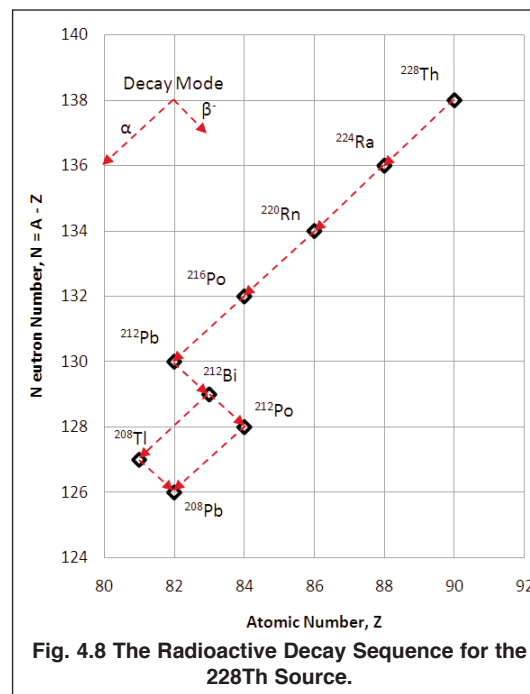

Fig. 4.8 The Radioactive Decay Sequence for the ^{228}Th Source.

Parent Isotope	Half-Life	Decay Type	Alpha or Beta Energies in MeV and (Percent of Decays)	Daughter Isotope
^{228}Th	191 y	α	5.423 (71%), 5.341 (28%)	^{224}Ra
^{224}Ra	3.64 d	α	5.68 (94%), 5.45 (6%)	^{220}Rn
^{220}Rn	55 s	α	6.29 (100%)	^{216}Po
^{216}Po	0.15 s	α	6.78 (100%)	^{212}Pb
^{212}Pb	10.6 h	β^-	0.58 max (14%), 0.33 max (81%), 0.15 max (5%)	^{212}Bi
^{212}Bi	60.6 m	α	6.09 (10%), 6.05 (25%)	^{208}Tl
		β^-	2.27 max (54%), 1.55 max (5%), 0.93 max (1.4%), 0.67 max (2.2%)	^{212}Po
^{208}Tl	3.10 m	β^-	1.80 max (49%), 1.52 max (23%), 1.29 max (24%), 1.04 max (4%)	^{208}Pb
^{212}Po	304 ns	α	8.78 (100%)	^{208}Pb

Experiment 4

Alpha Spectroscopy with Silicon Charged-Particle Detectors

Procedure

1. This experiment relies on an accurate energy calibration for identifying peaks in the spectrum. If the energy calibration from the previous measurements has not been disturbed, that calibration can be extended to this experiment. If there is any reason to believe that the prior calibration is no longer valid, implement one of the previously studied calibration methods before proceeding any further. It will be most convenient for this experiment if a combination of pulser and alpha peaks are employed with the MAESTRO energy calibration feature. This will enable the cursor to directly read the energies of the peaks in the ^{228}Th spectrum.
2. Reduce the detector bias voltage to zero. Open the vent valve on the 807 Vacuum Chamber and allow the chamber to come up to atmospheric pressure. Open the chamber, remove any prior source and install the ^{228}Th source. Pump the vacuum back down to $\sim 500\ \mu\text{m}$ (approximately 2 minutes pumping time). Again, slowly increase the detector bias to its proper operating value. Turn off the 480 Pulser.
3. Accumulate the spectrum until all the peaks of interest are statistically well defined.
4. Use the cursor to read the energy of each peak, and identify the radioisotope generating that alpha emission by reference to Table 4.2.
5. Save a copy of the spectrum on hard disk in case you will need to recall it later.

EXERCISE

Plot the spectrum so that the energies and isotopic origins can be marked on the peaks. The most efficient way to achieve this goal is to use the MAESTRO option to save (export) the spectrum as an ASCII file. If you plan to work on the report after leaving the laboratory, save this ASCII file on a transportable medium such as a CD or a memory stick. The ASCII file can be imported into an Excel spreadsheet. Choose the Tab and Space Delineated option in Excel when importing the file. This generates the file header and the channel-by-channel counts as a table in Excel. That data can be plotted with the Excel graphing options, and labeling can be inserted on each peak in the spectrum. The resulting Excel graph can be imported into your lab report and printed.

References

1. G. F. Knoll, Radiation Detection and Measurement, John Wiley and Sons, New York (1979).
2. G. Bertolini and A. Coche, Eds., Semiconductor Detectors, American Elsevier Publishing Co., Inc. (1968).
3. G. Dearnaley, "Nuclear Radiation by Solid State Devices", J. Sci. Instrum. 43, 869 (1966).
4. See: Introduction to Silicon Charged Particles at the ORTEC web site, www.ortec-online.com/Solutions/RadiationDetectors/index.aspx?tab=2.
5. J. L. Duggan, W. D. Adams, R. J. Scroggs, and L. S. Anthony, "Charged-Particle Detector Experiments for the Modern Physics Laboratory", Am. J. Phys. 35(7), 631 (1967).
6. C. M. Lederer and V. S. Shirley, Eds., Table of Isotopes, 7th Edition, John Wiley and Sons, Inc., New York (1978).
7. G. T. Ewan, "Semiconductor Spectrometers" (in progress), Nucl. Tech. and Instrum. 3, F. M. Farley, Ed., Elsevier, North Holland, New York (1968).
8. C. F. Williamson, J.P. Boujot, and J. Picard, Tables of Range and Stopping Power of Chemical Elements for Charged Particles of Energy 0.5 to 500 MeV, CEA-R-3042 (July 1966).
9. See the introduction to preamplifiers and the data sheet for the 142A at <http://www.ortec-online.com/Solutions/modular-electronic-instruments.aspx?tab=4>.
10. Eckert & Ziegler radioactive sources catalog under Products/Reference and Calibration at www.isotopes.com.
11. R. D. Evans, The Atomic Nucleus, McGraw-Hill, New York (1955).

Experiment 4
Alpha Spectroscopy with
Silicon Charged-Particle Detectors

Experiment 4
Alpha Spectroscopy with
Silicon Charged-Particle Detectors

Specifications subject to change
071315

ORTEC[®]

www.ortec-online.com

Tel. (865) 482-4411 • Fax (865) 483-0396 • ortec.info@ametek.com
801 South Illinois Ave., Oak Ridge, TN 37830 U.S.A.
For International Office Locations, Visit Our Website

AMETEK[®]
ADVANCED MEASUREMENT TECHNOLOGY